

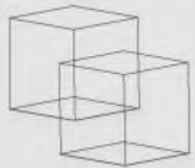

*DESIGNED WITH YOUR
REQUIREMENTS IN MIND*



Kent Industrial USA, Inc.
1231 Edinger Avenue
Tustin, CA 92780 USA
Tel: +.714.528.8526
General Inquiry: info@kentusa.com



CNC LATHES

*Full Line of High Quality CNC Lathes
to Meet Your Turning Challenges.*

ONE-PIECE FABRICATED BED

The massive bed is one-piece manufactured from high quality Meehanite cast iron, and stress relieved for deformation-free year after year.

Bedways are induction hardened to hardness of HRC 52~54, and precision ground to achieve high straightness accuracy.

Tailstock

The tailstock accommodates a MT#6 live center.
 Ø 105 mm quill diameter can hold workpiece firmly



Triple "V" and Flat Bedways

The bed is designed with triple "V" and one flat slideway to increase machining dependability and more high precision.

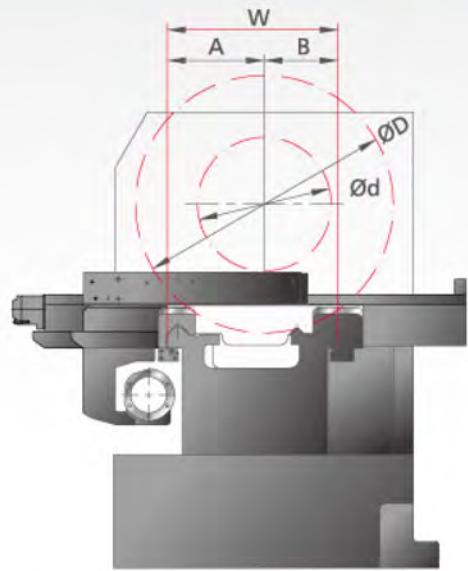
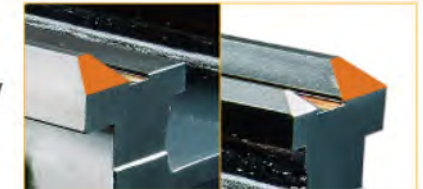

Perfect Ratio of Bed Width to Swing over Cross Slide > 0.5

	TA30	TA34
Swing over bed (D)	770	870
Swing over cross slide (d)	400	500
A	290	
B	220	
W	510	

X, Z-axis Ball Screws

X-axis ball screw:
 diameter Ø40mm, pitch 5mm

Z-axis ball screw:
 diameter Ø63mm, pitch 10mm



Dust Removing Hole

The dust removing hole in the bed allows chips to be delivered to the chip conveyor, located at the rear side of the machine.

Heavily Ribbed Bed for Increased Rigidity

The bed is scientifically ribbed to achieve ultra high rigidity and stability during cutting.



ADVANCED DESIGN CONCEPT TO MEET CUSTOMER REQUIREMENTS!



4" (A2-8)
High-speed Light Machining



6" (A2-11)
Heavy Duty Machining



9" (A2-15)
Pipe



12" (A2-20)
Pipe

Rigid Spindle Stock

Top Quality Material of Spindle
To ensure the spindle accuracy and durability, the spindle is precision machined from high quality chrome molybdenum alloy steel (SCM435~440)

Rigid Lubrication Tubes

The lubrication system employs rigid tubes to eliminate the heat expansion cold contraction problem and without breakage.

Hydraulic Disk Brake (Optional)

Conventional motor brakes create a reactive force to damage the parts in the controller. However, with the use of the optional disk brake, gears will not be damaged because inertia problem is eliminated.

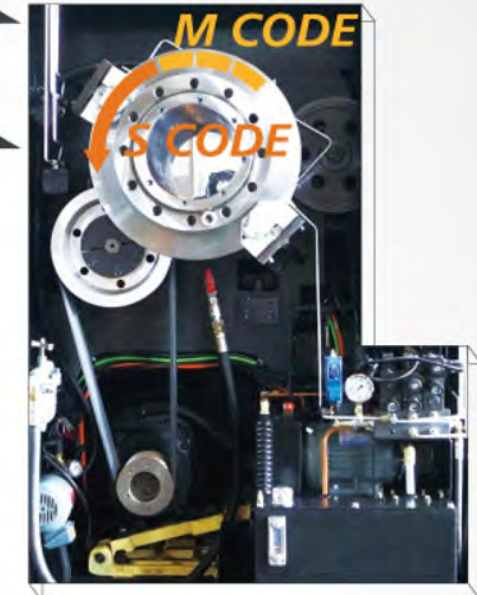

Integrated Motor and Pump

The hydraulic system integrates the motor and pump, which do not need to be dismantled prior to shipping and ensure an attractive appearance.

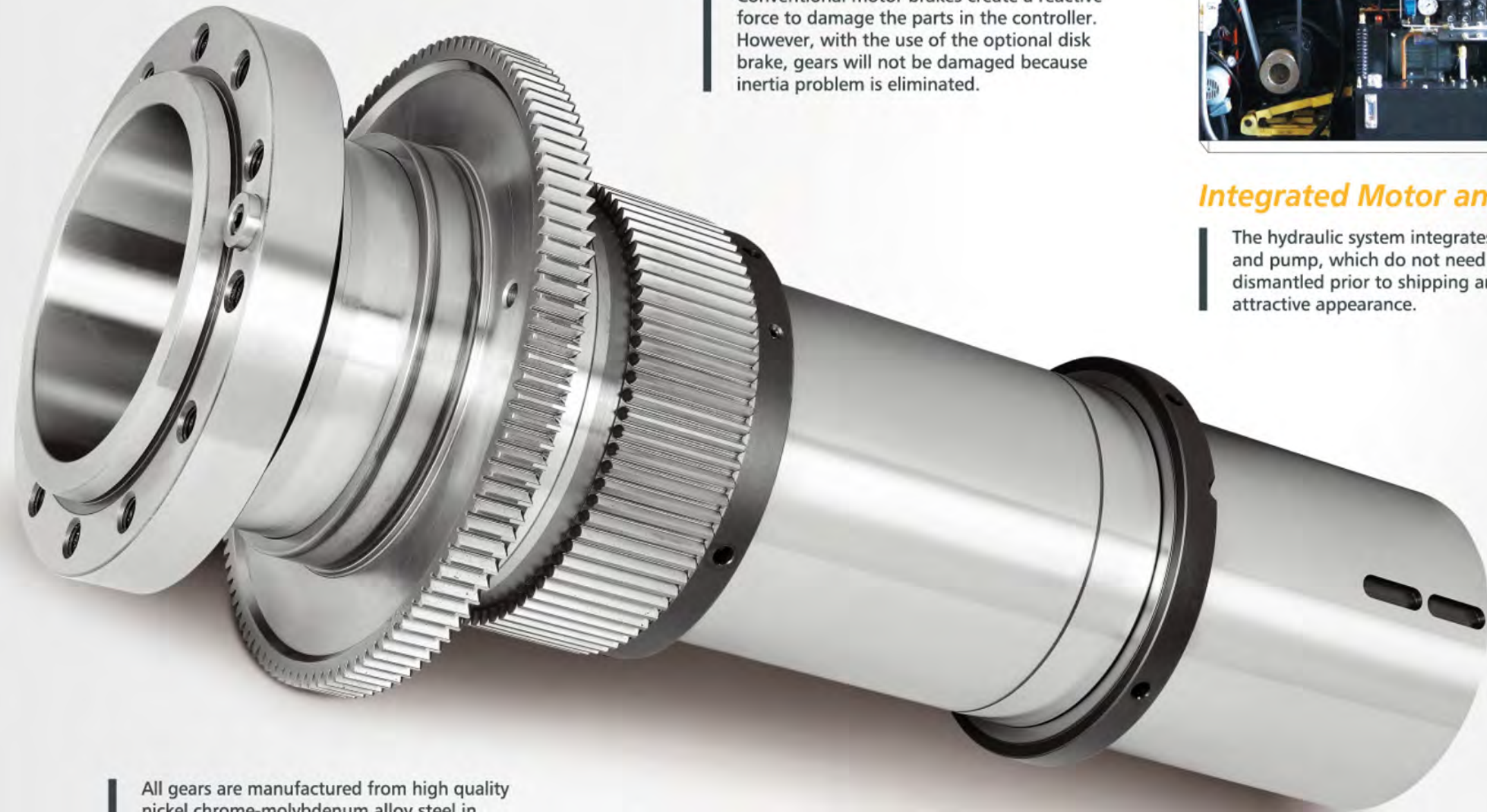

All gears are manufactured from high quality nickel chrome-molybdenum alloy steel in combination with a large module design.

With the increased tooth module and gear width, the gears have larger contact surfaces resulting in greater durability and longer lifespan.

Heavy Duty Gears
Module M3.5/M4

VARIOUS CONTROLS TO CHOOSE FROM FOR USER-FRIENDLY OPERATION

Kent CNC offers 3 world-famous brands of control to meet market demands.



FANUC



Siemens



Fagor

BRAND	FANUC	SIEMENS	FAGOR
Model	OiTd 8.4" LCD	828D 10.4" LCD	8055-TC 10.4" LCD
Spindle Power	18.5/22 Kw	22/33 Kw	22/33 Kw
X-axis Servo Motor	12Nm (3Kw)	16Nm (3.3Kw)	16.5Nm (5.2Kw)
Z-axis Servo Motor	22Nm (4Kw)	27Nm (4.85Kw)	27.3Nm (5.7Kw)



For lathes with two safety doors, there are two hand wheels on the safety door for two-axes simultaneous control.



User Friendly
Can be adjusted up and down by 100mm for users' height.

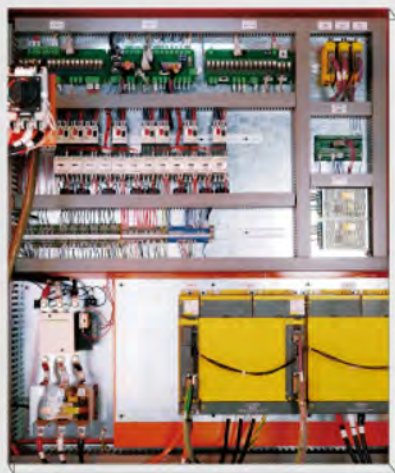

Self-developed Control Circuit

The Kent CNC self-developed PLC control integrates the most practical functions for lathe operations.

Our Electrical Control division designs the Industrial Power Distribution and Mechatronics. Then we own the machining database from many clients.

The control circuit is not only CE certified but also employs wire color identification complying with European regulations.

Wire Identification Meets European DESINA Regulations

DESINA (Distributed Standardised Installation technology) was set by Germany VDW, which specified wire and cable colors so as to increase appearance identification and wiring efficiency while reducing inspection and maintenance costs.



CHUCK

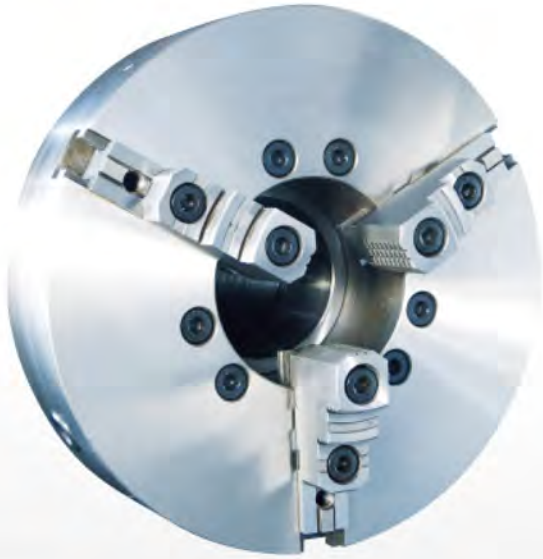

3 JAW Manual, Hydraulic Chuck Ø 16" ~ 32"

4 JAW Manual, Hydraulic Chuck Ø 15" ~ 32"

SPINDLE BORE	OUTER DIA	SIZE OF THE 2ND CHUCK
4"(A2-8) Hydraulic Chuck	Ø 15"	-
6"(A2-11) Manual Chuck	Ø 16" / 20"	Ø 20"
9"(A2-15) Manual Chuck	Ø 24" / 32"	Ø 24"
12"(A2-20) Manual Chuck	Ø 24" / 32"	Ø 32"

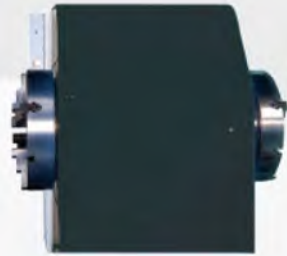

TURRET

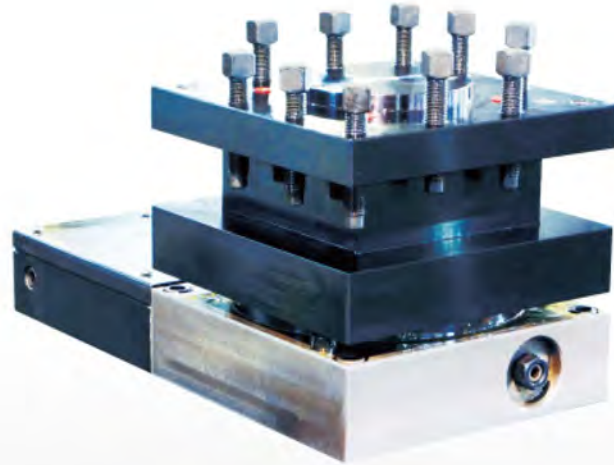

H4 Hydraulic Turret (Standard)

The H4 hydraulic turret holds 4 tools and can be quickly swivelled to cutting position.



H4-VDI Quick Change Hydraulic Turret (Optional)

The H4-VDI quick change hydraulic turret is a 4-way quick change turret, providing quick indexing.



STANDARD EQUIPMENT



3 JAW Chuck, Ø16



One Steady Rest Ø30-300mm



H4-250 Hydraulic Turret



Live Center



V8 Hydraulic Turret (Optional)

The V8 hydraulic turret holds 8 tools. It features high indexing accuracy, random tool selection and fast tool change.

RIGID SUPPORT



STEADY REST (Standard)

- 80mm quill diameter with heavy loaded bearing.
- Enhance rigidity and stable performance in machining.
- Ø30 - 300 mm
- Ø255 - 455 mm



ROLLER BRACKET

- Equipped on the machine especially for heavy duty large diameter workpieces.
- Has a wide range of clamping capacity 300mm-500mm.

ELEGANT AND NEAT APPEARANCE DESIGN

Cables and flexible guards are concealed at the top of the splash guard, and deployed from the machine top to bottom. This unique design avoids chips depositing, protects wires, and increases attractiveness.

Choice of Various Painting Colors

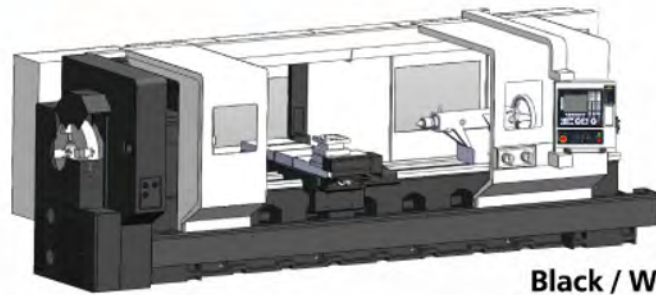

Black / White

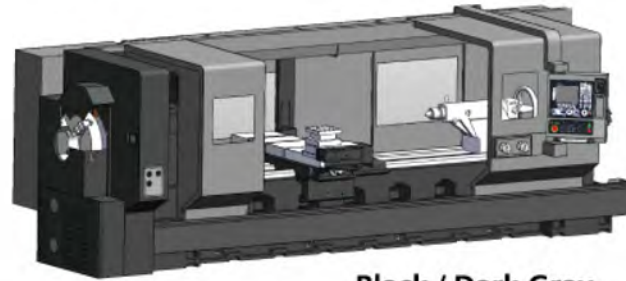

Black / Dark Gray

Fully Enclosed Splash Guard (Optional)

The machine appearance is designed with the concept of aesthetics and is not traditional and dull, while featuring a fashionable and simple appearance.



Container Loading for Saving Costs

Kent CNC cares for every detail, even the transportation cost is also taken into consideration. For saving on set-up time, the machine width design enables the machine to be loaded into a container without dismantling the rear splash guard.

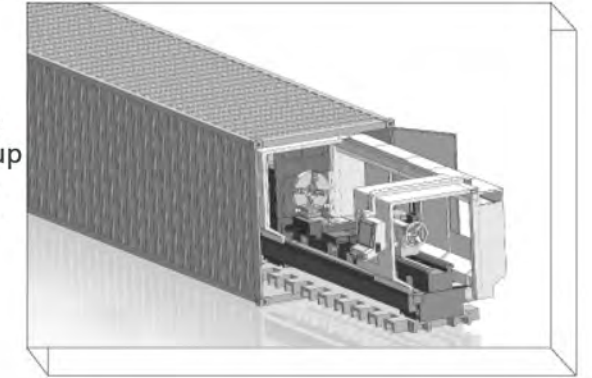

CONTAINER TYPE PER MODEL

TA30/34	*1000	20'DC*1
TA30/34	*2000	40'DC*1
TA30/34	*3000	40'DC*1
TA30/34	*4000	40'DC*1
TA30/34	*5000	40'DC*1



SPINDLE POWER & TORQUE CHART

SPINDLE MOTOR FANUC α18/6000i (18.5/22KW)								
Spindle Bore	4"		6"		9"		12"	
	RPM	Torque(Nm)	RPM	Torque(Nm)	RPM	Torque(Nm)	RPM	Torque(Nm)
M41	6	29500	6	29500	5	35400	4	44250
	12	15000	12	15000	10	18000	8	22500
	19	9237	19	9237	15	11700	12	14625
	25	6960	25	6960	21	8286	17	10235
M42	22	8045	22	8045	18	9833	15	11800
	45	4000	45	4000	45	4865	30	6000
	68	2581	68	2581	56	3134	46	3815
M43	91	1912	91	1912	74	2351	61	2852
	70	2529	70	2529	52	3404	40	4425
	140	1286	140	1286	104	1731	80	2250
M44	211	832	211	832	156	1125	120	1462
	281	619	281	619	208	837	160	1088
	249	711	249	711	184	962	142	1246
M44	499	361	499	361	369	488	284	634
	749	234	650	277	554	317	400	450
	998	174	-	-	600	292	-	-

SPINDLE MOTOR FANUC MODEL (Option) α22/7000i (22/26KW)								
Spindle Bore	4"		6"		9"		12"	
	RPM	Torque(Nm)	RPM	Torque(Nm)	RPM	Torque(Nm)	RPM	Torque(Nm)
M41	6	35000	6	35000	5	42000	4	52500
	12	17500	12	17500	10	21000	8	26250
	19	11053	19	11053	15	14000	12	17500
	25	8400	25	8400	21	10000	17	12353
M42	22	9545	22	9545	18	11667	15	14000
	45	4667	45	4667	45	4667	30	7000
	68	3088	68	3088	56	3750	46	4565
M43	91	2308	91	2308	74	2838	61	3443
	70	3000	70	3000	52	4038	40	5250
	140	1500	140	1500	104	2019	80	2625
M44	211	995	211	995	156	1346	120	1750
	281	747	281	747	208	1010	160	1313
	249	843	249	843	184	1141	142	1479
M44	499	421	499	421	369	569	284	739
	749	280	749	280	554	379	400	524
	998	210	998	210	600	349	-	-

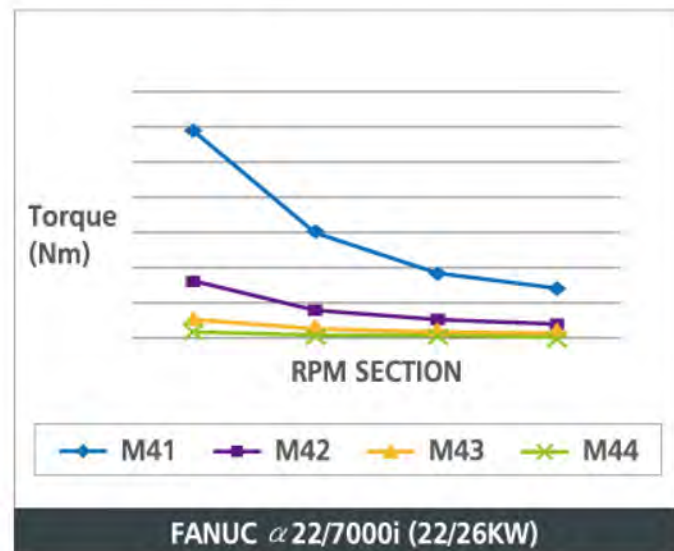
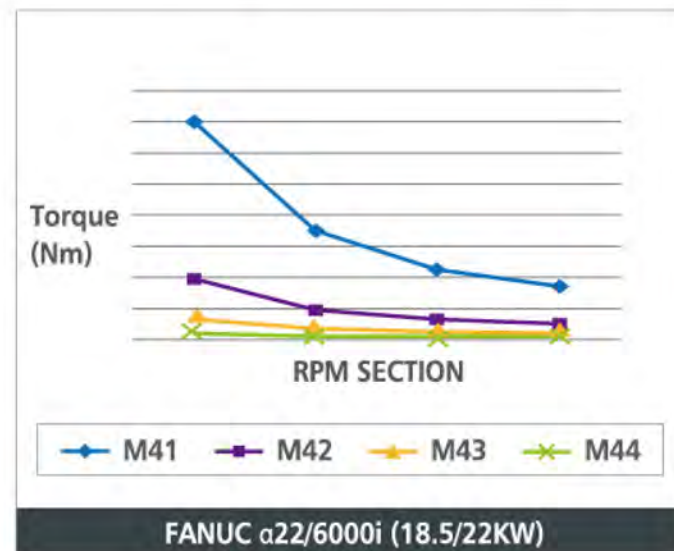

Model α18/6000i (18.5/22KW)
Motor speed [min⁻¹]

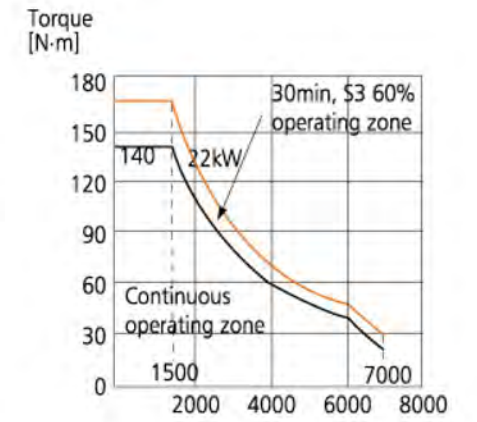
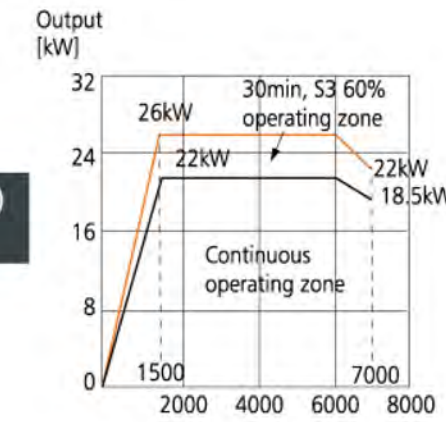

Model α22/7000i (22/26KW)
Motor speed [min⁻¹]

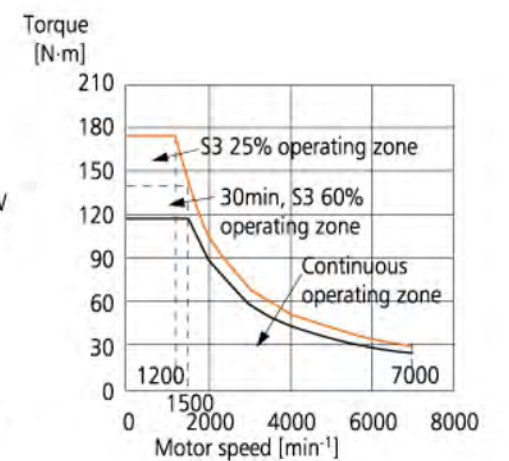
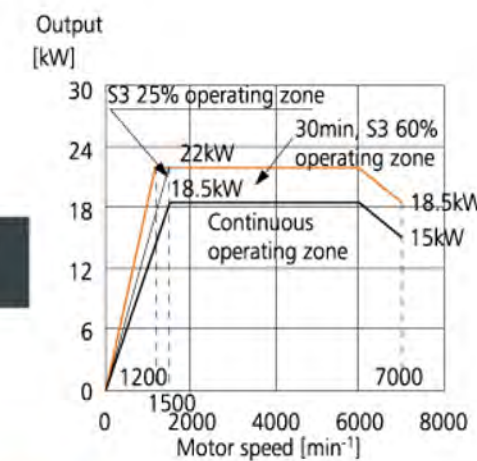

LOADING CAPACITY

MODEL	TA	TA	TA	TA
SPINDLE BORE	4" A2-08	6" A2-11	9" A2-15	12" A-20
TAILSTOCK QUILL DIAMETER	105 mm	105 mm	105 mm	105 mm
1 Max. load between centers	4000kgs	5000kgs	5500kgs	7000kgs
2 Max. load between centers plus 1 steady rest	4500kgs	6000kgs	6500kgs	7000kgs
3 Max. load between centers plus 2 steady rest	5500kgs	7000kgs	7500kgs	8500kgs
4 Max. load with one chuck only	1000kgs	2200kgs	2400kgs	2600kgs

DIMENSIONAL DRAWINGS

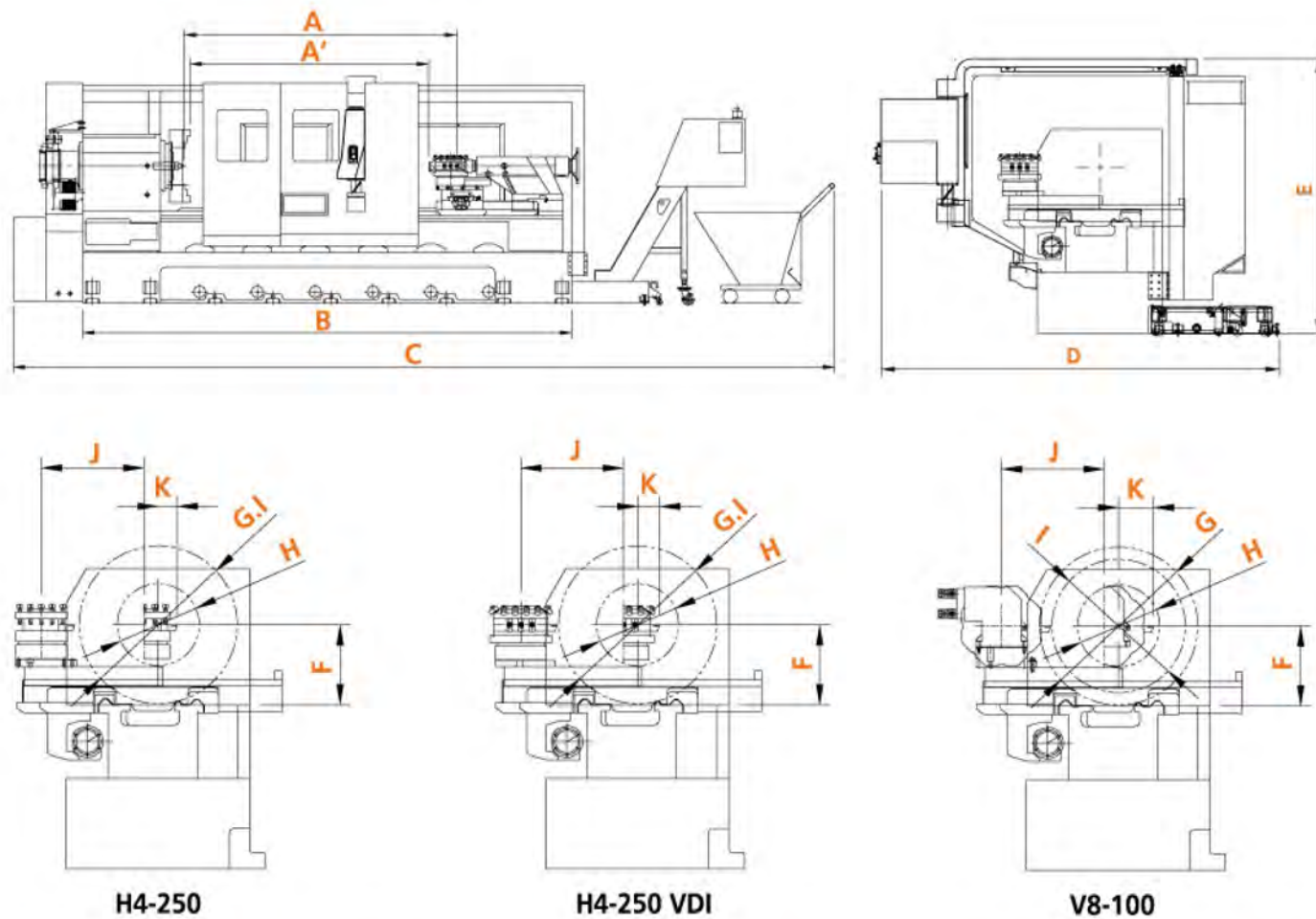

		1000	2000	3000	4000	5000
30	LxWxH(MM)	5400x2850x2100	6400x2850x2100	7400x2850x2100	8400x2850x2100	9400x2850x2100
	N.W/G.W (KG)	5820/6180	8230/8780	10640/11280	13050/13830	15460/16360
34	LxWxH (MM)	5400x2850x 2100	6400x2850x2100	7400x2850x2100	8400x2850x2100	9400x2850x2100
	N.W/G.W (KG)	6320/6680	8730/9270	11140/11780	13550/14330	15960/16860

Unit: mm

		TA 30		TA 34	
A	Distance Between Centers	1300 / 2300 / 3300 / 4300 / 5300		1300 / 2300 / 3300 / 4300 / 5300	
A'	Maximum Cutting Length	H4-250: 1120/2120/3120/4120/5120		H4-250: 1120/2120/3120/4120/5120	
		V8-100: 1035/2035/3035/4035/5035		V8-100: 1035/2035/3035/4035/5035	
		H4-VDI: 1060/2060/3060/4060/5060		H4-VDI: 1060/2060/3060/4060/5060	
		V12-100: 1035/2035/3035/4035/5035		V12-100: 1035/2035/3035/4035/5035	
B	Bed Length	3230 / 4230 / 5230 / 6230 / 7230		3230 / 4230 / 5230 / 6230 / 7230	
C	Machine Length	6100 / 7100 / 8100 / 9100 / 10100		6100 / 7100 / 8100 / 9100 / 10100	
D	Machine Width	2850		2850	
E	Machine Height	2000		2000	
F	Center Height	390		440	
G	Swing Over Bed	Ø770		Ø870	
H	Swing Over Cross Slide	Ø400		Ø500	
I	Maximum Cutting Diameter	H4-250:Ø770	V8-100:Ø650	H4-250:Ø770	V8-100:Ø650
		H4-250 VDI:Ø770	V12-100:Ø620	H4-250 VDI:Ø770	V12-100:Ø620
J	X-axis Traverse	500		500	
K	Cutting Distance Over Spindle Center	H4-250:100	V8-100:160	H4-250:100	V8-100:160
		H4-250 VDI:90	V12-100:180	H4-250 VDI:90	V12-100:180

SPECIFICATIONS

MODEL	TA 30	TA 34	
Swing Over Bed	770 mm (30")	870 mm (34")	
Swing Over Cross Slide	400 mm (19.7")	500 mm (23.6")	
Center Height	390 mm (15.4")	440 mm (17.3")	
Width of Carriage	885 mm(34.8")		
Width of Cross Slide	350 mm(13.8")		
Width of Bed	510 mm(20")		
Bed Way	3-V way with 1 flat way		
Distance Between Centers	1,300 mm(51") / 2,300 mm(90") / 3,300 mm(130") / 4,300 mm(169") / 5,300 mm(209")		
Control (4 choices)	Fanuc 0i-TD 8.4"LCD / Fagor 8055-TC 10.4"LCD SIEMENS 828D 10.4" LCD		
Spindle Power	Fanuc 18.5/22KW; Fagor22/33 KW; SIEMENS 22/33KW		
X-axis Servo Motor	Fanuc 12Nm(3KW) / Fagor 16.5Nm(5.2KW) SIEMENS 16Nm(3.3KW)		
Z-axis Servo Motor	Fanuc22Nm(4KW) / Fagor 27.3Nm(5.7KW) SIEMENS 27Nm(4.85KW)		
HEADSTOCK			
Spindle Bore	Ø105 mm(4")	Ø153 mm(6")	Ø230 mm(9")
Spindle Nose	A2-8	A2-11	A2-15
Spindle Speed	6~1000rpm	6~650rpm	5~600rpm
Spindle Center	MT #6		
TURRET			
Turret Mode	STD:H4-250 hydraulic /OPT: V8-100L hydraulic/ V12-100L/ H4-250 VDI		
Tool Size	STD:32 mm(1-1/4") OPT:25mm		
TAILSTOCK			
Quill Diameter	105mm quill-MT#6(STD)		
Quill Traverse	200 mm(7.9")		
Tailstock Center	MT# 6 live center		
Body Movement	Move by carriage		
Quill Movement	Electric / Manual		
FEED			
X-axis Rapid Traverse	6M/min		
X-axis Ballscrew Diameter	Ø40 mm*P5		
X-axis Feed Range	0.1 mm/min~3000 mm/min		
X-axis Traverse	500 mm		
Bed Length	3,230 mm(127") / 4,230 mm(166") / 5,230 mm(206") / 6,230 mm(245") / 7,230 mm(285")		
Z-axis Rapid Traverse	6M/min		
Z-axis Ballscrew Diameter	Ø63 mm*P10		
Z-axis Feed Range	0.1 mm/min~3000 mm/min		
Z-axis Traverse	1,000mm / 2,000 mm / 3,000 mm / 4,000 mm / 5,000 mm		
Z-axis Transmitting	1~3M: Directly (Coupling) 4~5M: 1:4 precision gear reducer		
STANDARD ACCESSORIES			
Lubricationsystem-carriage	Pressure-Relief Electric Lubricator 25W		
Lubricationsystem-spindle	1/4HP PUMP		
Color	MACHINE BODY/ SPLASH COLOR UP TO YOUR DEMAND		
Coolant Pump	1/2HP high pressure		
Hydraulic Pump	2 HP		
Chip Removing System	REAR CHIP CONVEYOR		
Guarding	REAR SPLASH GUARD+FRONT TWO DOORS / OPT:FULL GUARDING		

Note

1. X and Z axis actual cutting diameter will change when equipped with different turrets.
2. Spindle speed will change according to different motors.
3. Distance between centers will change based on installing different types of tailstocks.